



AB McLAUCHLAN :: WELLIVER METAL

Brush Washer

Layton Food Processing Brush Washer

THIS UNIT WAS DESIGNED TO GENTLY BRUSH WASH FRAGILE FOOD PRODUCTS SUCH AS STRAWBERRIES AND A NUMBER OF OTHER PRODUCTS, TO REMOVE LIGHT DEBRIS SUCH AS HAIR, SAND, MUD, AND LOOSE STEMS.

IT IS CONSTRUCTED OF ALL T-304 STAINLESS STEEL WITH NYLON FOOD GRADE TUFT BRUSHES. ALL BEARINGS ARE UHMW WHICH DO NOT REQUIRE ANY LUBRICATION. DRIVE IS A 1/2 HP WASH-DOWN DUTY 3 PHASE MOTOR.

IT ALSO HAS 20 FRESH WATER SPRAY NOZZLES TO REMOVE DEBRIS

ADJUSTABLE LEGS TO CONTROL ANGLE OF DECLINE.

ROD SCREEN DISCHARGE CHUTE.

WATER CATCH BASIN WITH DRAIN SPOUT.



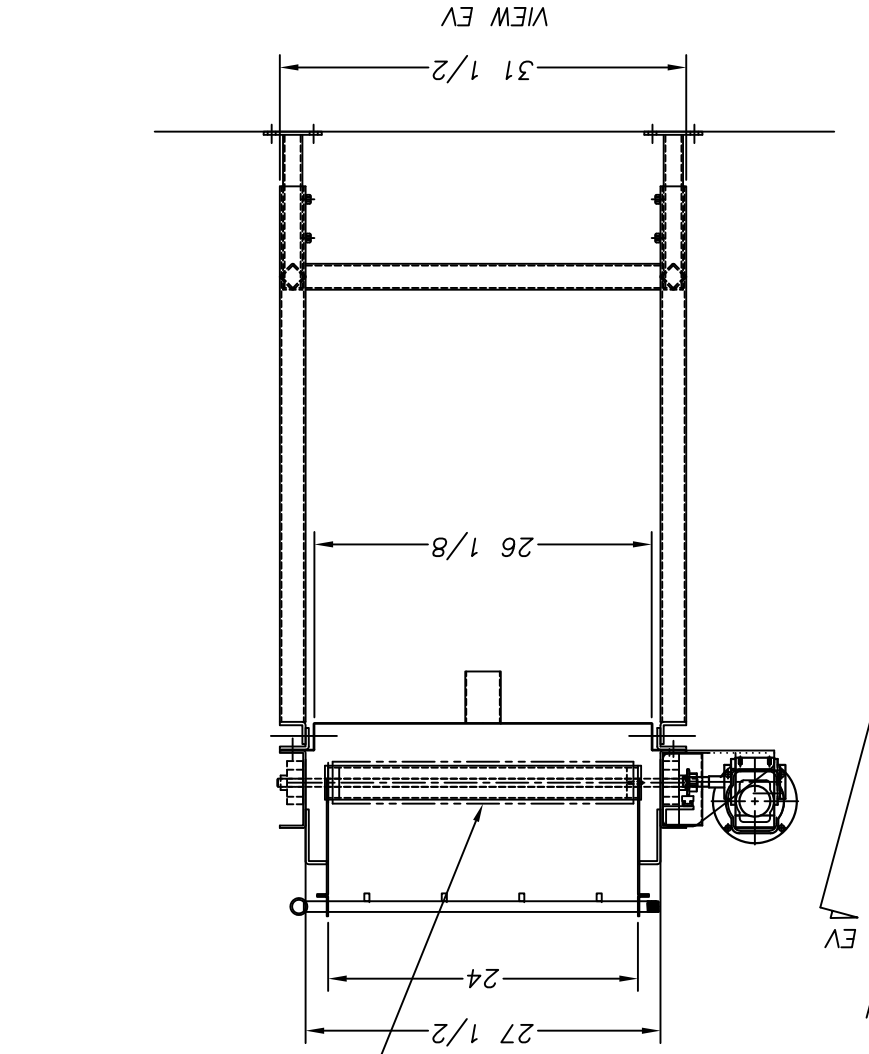

"GENTLE" NYLON
FOOD-GRADE BRUSHES

DISCHARGE ROD CHUTE
ONTO TABLE OR CONVEYOR

